



INTERNATIONAL JOURNAL OF ENGINEERING SCIENCES & RESEARCH TECHNOLOGY

Performance of a 3.3kV Resistive type Superconducting Fault Current Limiter

S.Vasudevamurthy¹, Ashwini.V²

¹ Department of Electrical and Electronics, Associate Professor, Dr. Ambedkar Institute of Technology, India

² Department of Electrical and Electronics, M.Tech Student, Dr. Ambedkar Institute of Technology, India
ashunatya03@gmail.com

Abstract

In today's technological world, electrical energy is one of the most important forms of energy and is needed directly or indirectly in almost every field. Increase in the demand and consumption of electrical energy leads to increase in the system fault levels, and it crosses the rated capacity of the existing circuit breakers. One solution to this problem is to use a current limiting device in the system. In view of this, it is desirable to introduce a reliable means of limiting the fault currents so that the circuit breakers open at lower fault currents without any damage. One of them is Superconducting Fault Current Limiter. It appears to be the most attractive option for such purposes. Superconducting fault current limiter (SFCL) based on high temperature Resistive type is an enabling technology for the extensive fault current limitation when compared to Conventional circuit breakers.

In this paper overview of the SFCL, modeling and simulation Studies of a 3.3kV single phase resistive type SFCL, to predict the performance of the Resistive type Superconducting Fault Current Limiter (SFCL) using MATLAB/SIMULINK is presented.

Keywords: Superconducting Fault Current Limiter (SFCL), Resistive Type SFCL, MATLAB/SIMULINK.

Introductions

A rapid growth in the power generation results in an increase in the fault levels and it crosses the rated capacity of the existing circuit breakers. Replacement of existing switchgears due to such increasing fault levels imposes high costs for the electric power utilities and their customers. In view of this, it is desirable to introduce a reliable means of limiting the fault currents so that the circuit breakers open at lower fault currents without any damage.

A Superconducting fault current limiter device reacts very rapidly, resets itself after a fault, and has minimal impact on system performance during normal operation.

Superconducting fault current limiters (SFCL) appear to be the most attractive option for limiting the fault current. Earlier SFCLs were made with low temperature superconductors (LTS) which were quite expensive and not reliable at higher levels of fault.

HTS applications operate at cryogenic temperatures, typically cooled by liquid nitrogen. Refrigeration systems are needed that are reliable, highly efficient and affordable. In recent years there has been a significant progress in the development of efficient cryo-refrigerators acting as recondensers in HTSFCL cryostats. At present worldwide R&D

efforts are in progress to develop HTSFCL based on 2nd generation (2G) YBCO coated conductors

The principal of the S-FCL is simple. A superconducting element is inserted in series with a line. During normal operating the system operates without any limitations because the resistance of the superconducting element is essentially zero, and it is possible to minimize the inductive impedance. However, during a fault when the fault current reaches many times the rated value, the superconducting element reverts rapidly to its normal state (i.e., its resistance increases to a defined value). The increased resistance/impedance limits the fault current to the desired level. Once the fault clears, the superconducting coil carries the system's normal current with zero resistance. During a fault when the superconducting element is in normal state, it warms up to a predetermined temperature.

Ideally an S-FCL should limit the fault current to a desired level during a fault and recover quickly after the fault has cleared.

Basic Characteristics of SFCL

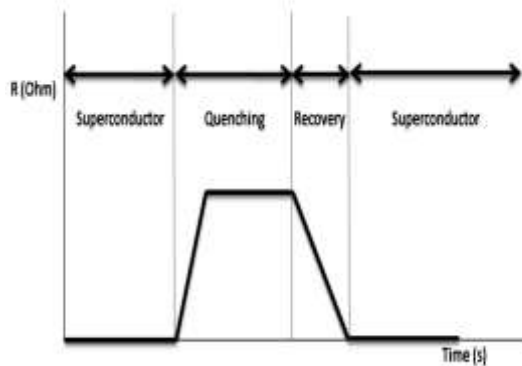

Figure 1.1: Basic characteristics of SFCL

Superconducting state is a state where an electrical conductor exhibits zero electrical resistance if the current flow through the material is below a certain threshold (the “critical current level”), when operating below certain temperature and external magnetic field (the so called “critical temperature, T_c ” and “critical field, H_c ,” range). If the current exceeds this critical level however, the superconductor will undergo a transition from its superconducting state to a resistive state. This transition is termed as “quenching”. SFCL’s utilize this property of Superconductors losing its property above the critical current.

In quenching state, the resistance of SFCL increases linearly and reaches a value, which will remain constant throughout the quenching period. As long as the heat generated (I^2R loss) during the resistive stage does not damage the superconductor, the superconductor can be brought back to its superconducting state, if sufficient cooling is provided. The quenching of a superconductor and subsequent ‘recovery’ to a superconducting state corresponds to a “variable resistance” effect, which is ideal for current limiting applications. Cryogenic cooling shall be provided to dissipate the heat quickly to lower the temperature of the superconductor to within its critical temperature range.

SFCL Technology

The SFCLs has the ability to reduce fault current levels within the first cycle of fault current level. The first cycle suppression of fault current by SFCL results in an increased transient stability of power system carrying higher power with greater

stability. SFCLs are self regulating in the event of fault and are fail safe.

SFCL can give an effective fault limitation without any degradation. Typical operation sequence of an SFCL is shown in figure1.2. From figure 1.2; it is observed that the fault condition occurs for a short time period when a nominal current was flowing in the electric system. The fault current can be 10 to 20 times higher than the nominal current. In presence of an SFCL, fault current can be limited very quickly to a level where the circuit breakers can work safely. After that SFCL goes for a recovery operation and comes back to the initial stage where it carries nominal current and voltage.

If the required current limiting performance is specified as ratio of the short-circuit current with fault current limiter operation to the short-circuit current without fault current limiter operation, it should be clearly indicated whether this ratio refers to the short-circuit current at the fault location or the short-circuit current flowing through the fault current limiter. In case of fault current limiters which introduce a resistance into the circuit the fault current limiter not only limits the fault current but also shifts its phase which leads to an additional current limiting effect when a limited and an unlimited fault current sum up to a total short-circuit current. The following figure 1.2 depicts the functionality of an SFCL in case of a fault event.

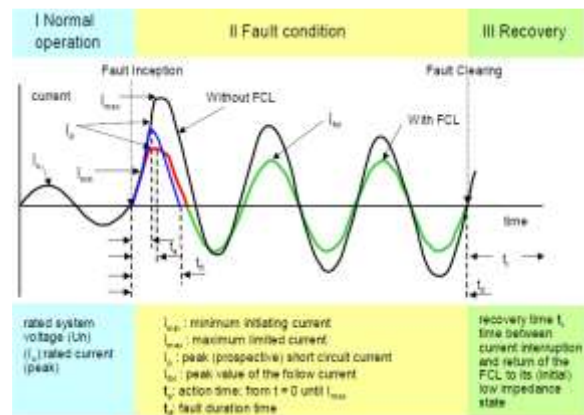

Figure 1.2: The functionality of an SFCL in case of fault event

Resistive Type SFCL

Resistive SFCLs utilize the superconducting material as the main current carrying conductor under normal grid operation. The principle of their operation is shown in the one-line diagram below (Figure 1.3).

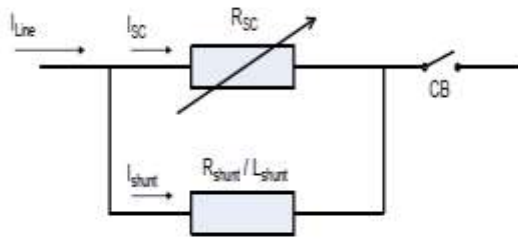

Figure 1.3: Resistive type SFCL with shunt element

When the current passes through the superconductor and when a high fault current begins, the superconductor quenches: it becomes a normal conductor and the resistance rises sharply and quickly. This extra resistance in the system reduces the fault current. Superconductor quenches under excessive fault current reverting to a normal conductor, inserting resistance.

The current level at which the quench occurs is determined by the operating temperature, and the amount and type of superconductor. The rapid increase in resistance produces a voltage across the superconductor and causes the current to transfer to a shunt, which are a combined inductor and resistor. The shunt limits the voltage increase across the superconductor during a quench. In essence, the superconductor acts like a switch with millisecond response that initiates the transition of the load current to the shunt impedance. Ideally, the incipient fault current is limited in less than one cycle.

Early resistive SFCL designs experienced issues with “hot spots”, or non-uniform heating of the superconductor during the quench. This is a potential failure mode that occurs when excessive heat damages the HTS material. Recent advances in procedures for manufacturing HTS materials coupled with some creative equipment designs have reduced the hot-spot issue. The grid characteristic of the resistive SFCL after a quench is determined by the shunt element.

Thus, because the shunt is typically quite reactive, a resistive SFCL typically introduces significant inductance into the power system during a fault. During the transition period when current is being transferred from the superconductor to the shunt, the voltage across the combined element is typically higher than it is after the current has transitioned to the shunt. The dynamics of this process depend on the two elements and their mutual inductance.

The quench process in resistive SFCLs results in heat that must be carried away from the superconducting element by the cryogenic cooling system. Typically, there is a momentary temperature rise in the superconducting element that causes a loss of superconductivity until the cryogenic system can restore the operating temperature. This period of time is known as the recovery time.

Theory of Fault Current Limiter

Consider a simple power system model, consisting of a source with voltage V_s , internal impedance Z_s , load Z_{load} , and fault impedance Z_{fault} .

In steady state,

$$I_{line} = \frac{V_s}{Z_s + Z_{load}} \tag{1}$$

When a fault occurs in a system,

$$I_{fault} = \frac{V_s}{Z_s + Z_{fault}} \tag{2}$$

Where, $Z_{fault} \ll Z_{load}$

Since the supply impedance is much smaller than the load impedance, Equation 2 shows Z_s that the short circuiting of the load will substantially increase the current flow. However, if a FCL is placed in series,

$$I_{fault} = \frac{V_s}{Z_s + Z_{FCL} + Z_{fault}} \tag{3}$$

Equation 3 tells that, with an insertion of a FCL, the fault current will now be a function of not only the source Z_s and fault impedance Z_{fault} , but also the impedance of the FCL. Hence, for a given source voltage and increasing Z_{FCL} will decrease the fault current I_{fault} .

Modelling And Simulation Results Of A 3.3kv/200A Single Phase Resistive Type Superconducting Fault Current Limiter

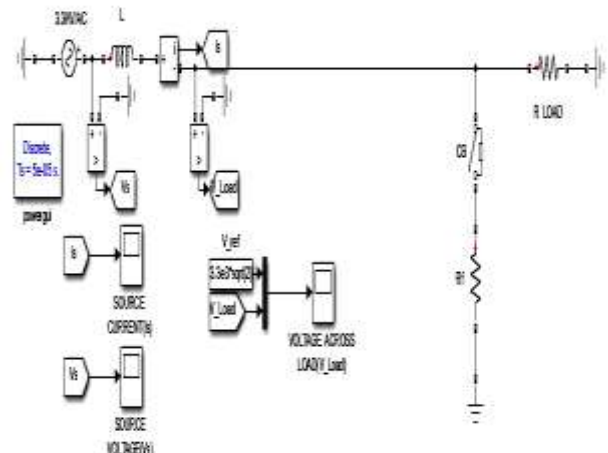

Figure 1.4: Model of a 3.3KV/200A single phase without SFCL

A simple single phase 3.3 KV, 200A, 50Hz power system network without High Temperature Superconducting Fault Current limiter (HTS FCL) and creating fault at exactly 0.3 sec has been simulated with Matlab Simulink and the result is shown in below figure. From the result it is analyzed that at exactly 0.3 sec sudden increase in fault current from 200A to 5000A and decrease in output voltage from 4666V to 4165V after creating fault in the electric network.

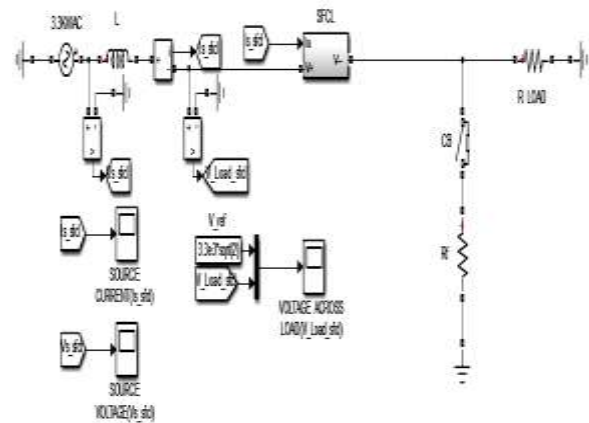

Figure 1.8: Model of a 3.3KV/200A single phase with SFCL

In the same single phase 3.3KV, 200A, 50Hz power system network High Temperature Superconducting Fault Current limiter (HTS FCL) is connected and creating fault at exactly 0.3 sec has been simulated with Matlab Simulink and the result is shown in below figure. From the result it is analyzed that at exactly 0.3 sec the fault current is reduced from 5000A to 3750A after creating fault in the electrical network.

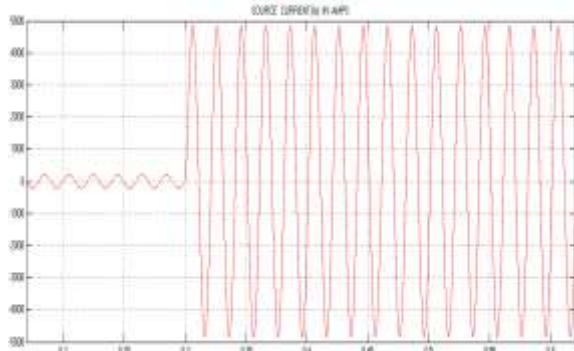

Figure 1.5: Source Current without SFCL

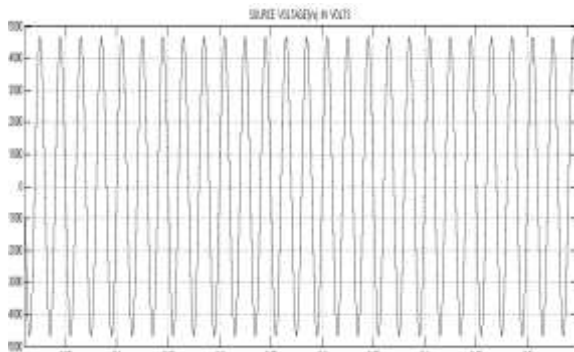

Figure 1.6: Source Voltage without SFCL

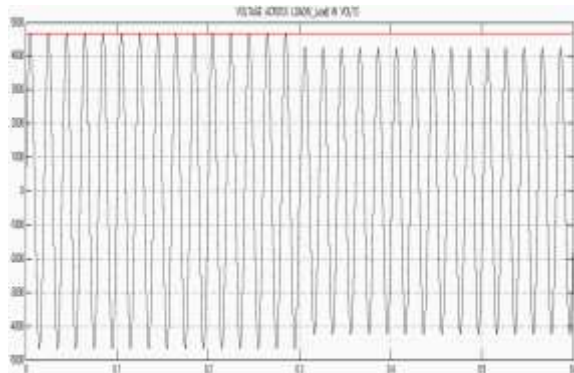

Figure 1.7: Voltage across the load without SFCL

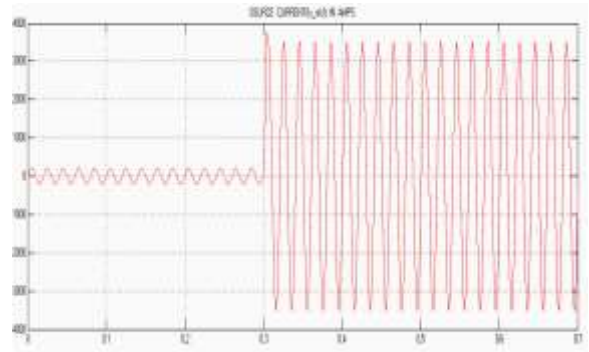

Figure 1.9: Limited fault current with SFCL

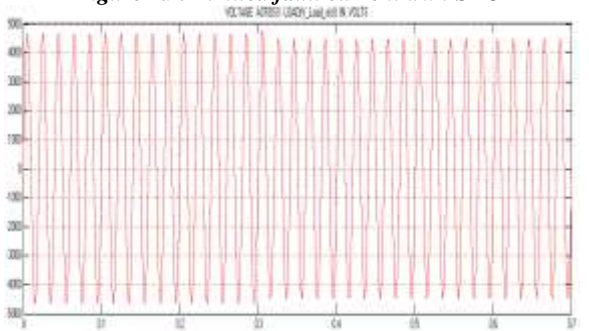

Figure 1.10: Voltage across the load with SFCL

5. Hui D et al, "Development and test of 10.5 kV/1.5 kA HTS fault current limiter", *IEEE Trans. Appl. Supercond.*, Vol. 16, pp.687–690, 2006.

6. Umer A.Khan, J.K.Seong "Feasibility Analysis Of The Positioning Of Superconducting Fault Current Limiters For The Smart Grid Application Using Simulink", *IEEE Trans. Appl. Supercond.*, Vol. 21, No.3, June 2011.

SFCL Model

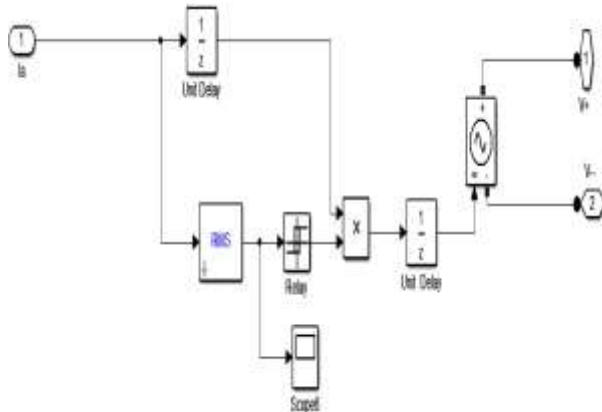

Figure 1.11: The Resistive type SFCL model developed in MATLAB simulink.

The SFCL works as follows. First, SFCL model calculates the RMS value of the passing current and then compares it with the triggering current value. Second, if a passing current is larger than the triggering current level, SFCL's resistance increases to maximum impedance level in a pre-defined response time. Finally, when the current level falls below the triggering current level the system waits until the recovery time and then goes into normal state.

Conclusion

In this paper simple single phase, without and with High Temperature Superconducting Fault Current Limiter (HTSFCL), and creating fault at 0.6sec has been simulated using Matlab simulink. Output results of the simulation is analysed and the results shows that with HTS FCL optimizes the fault current, and comparatively reliable than circuit breakers, where circuit breakers can handle the fault up to some voltage levels. SFCLs can be used for higher level of faults.

References

1. *Superconducting Fault Current Limiters: Technology Watch 2009*. EPRI, Palo Alto, CA: 2009. 1017793.
2. "Application of Fault Current Limiters"- Department of Business Enterprise & Regulatory Reform, 2007.
3. Bednorz J G and Müller K A, "Possible high T_c superconductivity in the Ba La-Cu-O system" *Z. Phys. B*, Vol. 64, 189–193, 1986.
4. Paul W, Lakner M, Rhyner J, Unternährer P, Baumann T, Chen M, Widenhorn L and Guérig A, "Test of 1.2 MVA high- T_c superconducting fault current limiter", *Inst.*